

Rope Grab

User's Guide for Rope Grab

LIN-RG58
LIN-RG34

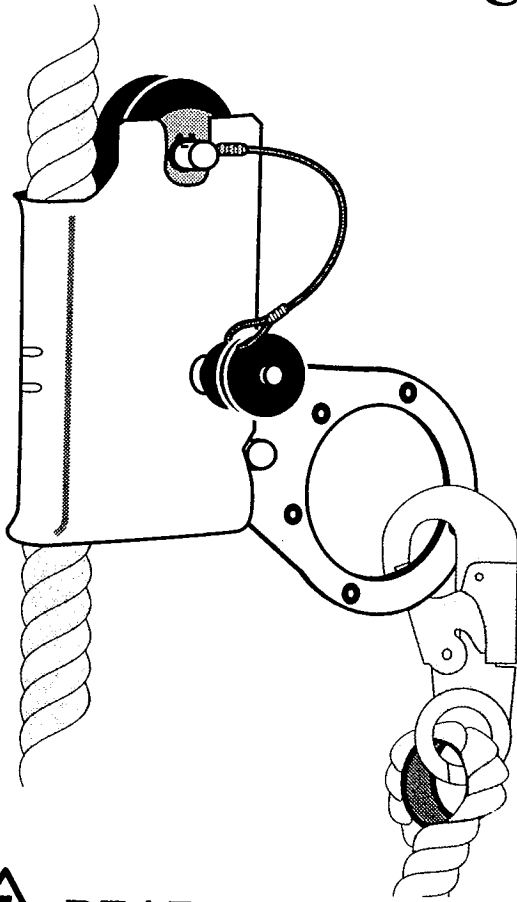

! READ THIS WARNING FIRST !

It is imperative for safety and efficiency of operations that this manual be read and fully understood by the worker before using any fall arrest or travel restraint system. ALL instructions contained herein must be carefully read and strictly followed.

A fall could result in serious injury or death. Do not use any equipment unless properly trained.

AVERTISSEMENT

Il est essentiel pour sa sécurité que l'utilisateur comprenne intégralement le présent guide avant d'utiliser le dispositif. Une mauvaise compréhension de ce guide peut entraîner un risque mortel. L'utilisateur qui ne comprend pas couramment l'anglais doit recevoir, l'information équivalente d'un spécialiste de sécurité ou de son superviseur.

ADVERTENCIA

Es necesario, para su propia seguridad que el usuario lea y comprenda intergramente este manual antes de utilizar el dispositivo. Si no se asimila bien este manual, puede tener como consecuencia riesgo mortal. Si el usuario no comprende suficientemente el inglés, es necesario que tenga la información equivalente por parte de un especialista en seguridad o de su responsable superior.

The Gripgrab® rope grab model #2267 is only part of a total fall protection or travel restraint system, and the use of compatible hardware and components is mandatory. The lifeline construction, materials, elongation and strength must meet federal, state, local or provincial regulations before being incorporated in a personal fall protection or travel restraint system. If you have any concerns or questions, please contact your distributor or Tractel Ltd.

 **Tractel** Ltd.
Fallstop Division

IN AN ENVIRONMENT WHERE A FALL HAZARD EXISTS, SAFETY IS A MATTER OF LIFE OR DEATH FOR WORKERS AND BYSTANDERS. THIS WARNING IS YOUR SHARE OF DUTIES FOR ACHIEVING SAFETY.

Your Duty to Understand and Comply

1.1 It is the worker's and their employer's responsibility to strictly conform to the following warnings.

1.2 Under whatever conditions, should you hand over any components of a fall arrest or travel restraint system to a party operating out of your control, you must provide a clean copy of this guide and draw the other party's attention that strictly following all the instructions therein is a matter of life or death.

1.3 Before using any fall arrest or travel restraint system, the worker and employer must become aware of all the requirements of federal, state, local and provincial safety regulations applicable to the use of the fall arrest or travel restraint system and any component thereof. Components of a fall arrest or travel restraint system must be compatible and recommended by Tractel Ltd. or the manufacturer of the device/system.

1.4 Never use fall arrest or travel restraint system or any component for any applications other than specified by the instructions supplied by the manufacturer of that device. Do not alter or adapt the equipment in any way.

1.5 The operator or user assumes the risk of injury if hurt because of failure to follow manufacturer's instructions.

1.6 Any harness, lanyard, rope grab, lifeline or hardware which has been subjected to fall arresting service must be removed immediately and not be reused. The device must be destroyed and replaced.

1.7 The combination of the user's weight, clothing and tools may not exceed 310 lbs. (140 kg). If this weight is exceeded the performance and safety of the rope grab cannot be guaranteed.

Your Duty to Inspect and Maintain

2.1 Keep this guide available at all times for easy reference whenever required. Extra copies are available from Tractel Ltd.

2.2 Carefully take notice of all labels affixed to fall arrest or travel restraint systems. Never use any equipment if any label normally fixed on fall arrest or travel restraint components are obscured or missing. Tractel Ltd. will supply extra labels for Fallstop® products at customer's request.

2.3 Every time a fall arrest or travel restraint system is used, check prior to proceeding that the components of system are complete, compatible and in good working condition.

2.4 Careful and regular inspection of the fall arrest or travel restraint system's installation is part of the safety requirements. If you have any questions, contact Tractel Ltd.

Your Duty to Train and Control People

3.1 A worker must not be assigned to a job when a fall arrest or travel restraint system is required, if that worker is not:

- a) mentally and physically fit for the purpose, specially at heights or in confined spaces;
- b) free from the influence of alcohol or drugs;
- c) competent for the job to be performed;
- d) familiar with the equipment and all applicable safety rules, requirements or regulations;
- e) trained for working under the above requirements.

3.2 Except for the operations described in this manual, the maintenance as well as repair of Fallstop® equipment must be exclusively done by authorized (in writing) Tractel Ltd. dealers or by Tractel Ltd.

3.3 Never let a fall arrest or travel restraint system be managed or operated by anyone other than authorized and assigned persons to the job. While out of operation, keep systems installed or stored out of reach of unauthorized persons.

3.4 Training workers includes setting up rescue procedures should a fall occur during a job prior to putting the systems into operation. Such procedures must be set up by a qualified person or technical consultant, according to work conditions.

3.5 Every job must be placed under the control of a person having the required qualification and authority for checking that all the instructions prescribed by this manual be regularly and efficiently carried out.

Your Duty Beyond the Fall Arrest or Travel Restraint System

4.1 Components of the installation other than rope grab must meet the requirements of the applicable regulations and requirements. They must be of the proper quality and must be assembled to form a safe and efficient fall arrest or travel restraint system.

4.2 Anchor points are to be stable, sufficiently strong and in accordance with federal, state, local and provincial regulations.

4.3 All requirements in strengths and resistance must be obtained with the necessary safety coefficients.

4.4 Prior to commencing the job, all the calculations, design and subsequent work necessary to the above requirements must be made by a qualified person on the basis of technical information regarding the site.

Your Duty to Avoid Taking Chances

5.1 For any job to be performed, consider and control the specific risks related to the nature of the job.

5.2 After inspection, should you decide that a fall arrest or travel restraint system or any component is no longer to be used,

take precautions in disposing of it so that it cannot be reused.

5.3 During rescue, the line or lines should be attached only to the single-mounted back D-ring and/or to both shoulder mounted D-rings.

THIS BOOKLET IS NEITHER A REGULATIONS COMPLIANCE GUIDE NOR A GENERAL TRAINING GUIDE FOR FALL ARREST OR TRAVEL RESTRAINT SYSTEMS. YOU MUST REFER TO INSTRUCTIONS DELIVERED BY MANUFACTURERS OF THE PIECES OF EQUIPMENT INCLUDED IN YOUR SYSTEM. WHENEVER CALCULATIONS AND SPECIFIC INSTALLATIONS ARE REQUIRED, THE WORKER SHOULD BE PROFESSIONALLY TRAINED TO THAT END AND SECURE RELEVANT INFORMATION PRIOR TO COMMENCING SUCH WORK.

Function and Description

6.1 **Function:** The Gripgrab® model #2267 is designed to be incorporated in a fall arrest or travel restraint system where worker mobility and fall protection is required. This rope cam lever grab is designed so that it can be moved freely for adjustment along a Fallstop® recommended synthetic lifeline, and in the event of a slip or fall the cam lever will lock onto the lifeline, restraining or arresting a fall. These are some example of situations using a rope grab: working within a scaffolding structure, on a suspended platform, climbing ladders, etc. (see Figure 1).

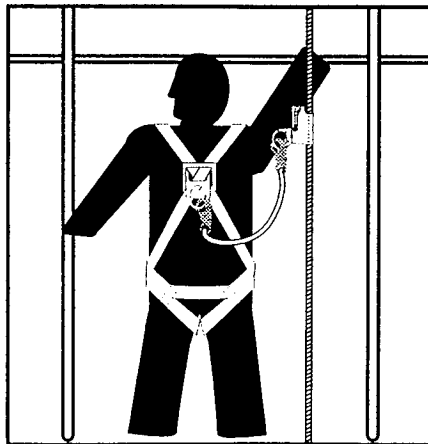
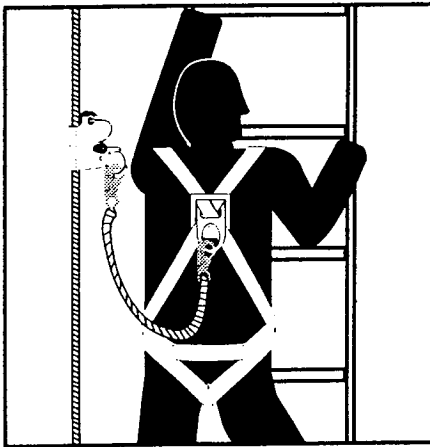

Figure 1

6.2 **Description:** LIN-RG58 Gripgrab® model #2267 is a cam lever rope grab recommended for 5/8 inch (16 mm) diameter 3 strand polypropylene, nylon, or polyblend, or static kernmantle lifeline. It is not to be used with manila or cotton rope.

LIN-RG34 Gripgrab® model #2267 is a cam lever rope grab recommended for 3/4 inch (19 mm) diameter 3 strand polypropylene, nylon, or polyblend, or static kernmantle lifeline. It is not to be used with manila or cotton rope.

WARNING

The Gripgrab® model #2267 is a fall arresting device. It is not a descent control device and should never be used for emergency escape or self-rescue. It has no speed control mechanism. If a fall occurs and you are suspended by the rope grab and lifeline, await rescue, DO NOT MANIPULATE the grab.

Limitation of the Equipment

7.1 One worker per Gripgrab® rope grab and per personal fall protection system.

7.2 **Hands Free Operation:** Always position the Gripgrab® rope grab at shoulder level to limit the free fall distance. Do not hold the Gripgrab® rope grab's cam lever in the open position while moving or at rest. Holding the Gripgrab® rope grab's cam lever in the open position could interfere with proper operation should a fall occur. The lifeline should be anchored or weighted so the rope grab can freely move for adjustment along the lifeline.

7.3 **Capacity:** The Gripgrab® rope grab is rated 310 lbs. (140 kg). The combination of the user's weight, clothing and tools may not exceed 310 lbs. (140 kg).

7.4 **Corrosion:** The Gripgrab® rope grab is designed using corrosion resistant materials but should not be left for long periods of time in environments where corrosion could take place. If corrosive environments are unavoidable, increase frequency of inspection to insure that integrity of the rope grab remains uncompromised.

7.5 **Electric Hazards:** Take extreme caution when working near or around high voltage power lines: electricity could pass through the Gripgrab® rope grab, lifeline or connecting components resulting in electrocution.

7.6 **Heat:** Do not use this Gripgrab® rope grab in environment exceeding 200°F (93°C).

7.7 **Impact:** Any Gripgrab® rope grab subjected to arresting a fall shall be removed from service and destroyed. Never use a single latching snap hook for an attachment in any personal fall arrest or travel restraint system.

7.8 **Life:** Any Gripgrab® rope grab showing wear or degradation shall be removed from service and returned to authorized dealer for inspection and repair. See inspection information (section 12) for further information.

System Components Requirements

8.1 **Anchor System:** An anchorage point is a secure point of attachment for lanyards or lifelines. It has to be independent of the means of supporting the worker and must have been identified by a qualified person. For fall arrest, the anchor point must support a minimum of 5,400 lbs. (24 kN) per attached worker. Consult governing regulations as revisions occur.

8.1.1 Every anchorage point must be selected with care. The anchorage point location, in combination with the lanyard, should never permit a free fall of more than six (6) feet (see Figure 2). Always check for obstructions below the work area to make sure potential fall path is clear. When selecting an anchorage point, take into consideration that a deceleration device, such as a shock absorber, can elongate up to four (4) feet.

8.1.2 Always work directly under the anchorage point to avoid swing fall injury (see Figure 3).

8.1.3 Never use an anchor point which will not allow the snap hook keeper to close. Anchor must be compatible with snap hook and must not be capable of causing a load to be applied to snap hook keeper.

8.2 **Lifeline:** When selecting the lifeline, be aware of the elongation characteristics of the rope and take into account when determining if it will arrest a fall before reaching any obstruction or the ground. Check that in humid conditions the rope does not swell beyond its original size as to prevent the proper operation, sliding along, of the rope grab.

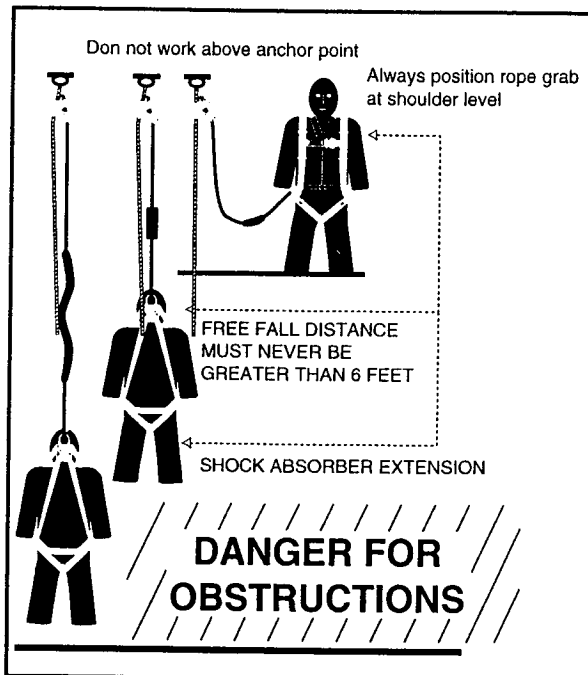

Figure 2

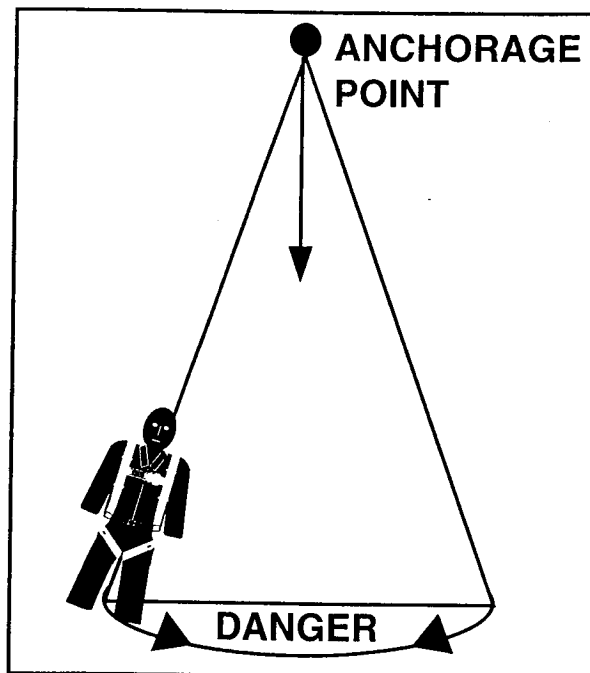

Figure 3

Do not work above the anchorage point and be aware that a pendulum fall could occur if the worker moves laterally from the anchorage.

8.2.1 When installed, the lifeline must maintain a minimum strength required by regulations (usually 5,400 lbs. or 24 kN). An eye splice termination is recommended where the lifeline attaches to the anchor point, since a knot on the rope may reduce its strength by 50%. Protect the lifeline from sharp edges or abrasions which could cut or damage the lifeline. The bottom end of the lifeline must be terminated such that the rope grab cannot slide off.

8.2.2 Lifeline construction should be selected with a firm lay. You should not be able to untwist lifeline without it returning to original size.

8.3 **Lanyard:** The Gripgrab® rope grabs perform more efficiently with a shorter lanyard. It is recommended that you use a 3 ft. (0.9 m) or shorter lanyard to minimize the free fall distance to avoid any injury. If the Gripgrab® rope grab is being

used for fall arrest, it is recommended that a shock absorbing lanyard be used to ensure that the impact forces do not exceed 1,800 lbs. (8 kN). Consult governing regulations as allowable free fall distance varies.

8.4 **Harness:** A full body harness is highly recommended for fall arrest. Attach the lanyard to the back D-ring when incorporating a full body harness in a personal fall arrest system.

8.5 **Belt:** If a belt is used it is recommended to utilize a lanyard that will maintain impact forces below 900 lbs. (4 kN), such as a shock absorbing lanyard.

NOTE: Certain jurisdictions do not allow the use of body belts for fall arrest. Consult governing regulations as revisions occur. Tractel Ltd. DOES NOT recommend that any belt be used for fall arrest.

Installing the GRIPGRAB® Rope Grab on the Lifeline

9.1 Ensure the diameter and type rope matches (the size) what is marked on the Gripgrab® rope grab.

9.2 Depress the button on the safety locking pin (a) out from main assembly. It should pull out from main assembly smoothly and quickly (see Figure 4).

9.3 Swing cam and lever assembly (b) up and away to open up rope channel (see Figure 4).

9.4 Install the rope grab on the lifeline with the arrow pointing up (see Figure 5).

9.5 Swing cam and lever assembly back into place and reinsert safety locking pin. It should push back into place and lock without sticking or jamming.

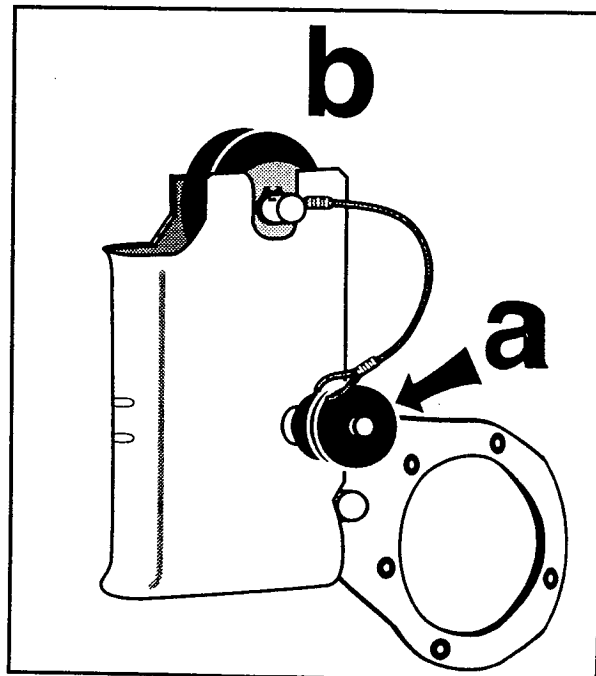

Figure 4

9.6 Ensure that lanyard is properly attached to the ring. Never use a single latching snap hook for an attachment in any personal fall arrest or travel restraint system.

9.7 The lifeline should be anchored or weighted down so that it remains taut and the grab move freely.

9.8 Test the Gripgrab® rope grab after installing on the lifeline by lifting and lowering the lanyard. The Gripgrab® rope grab should run up and down the rope smoothly. Next, pull down sharply on the lanyard and the rope grab should lock securely on the lifeline. If the Gripgrab® rope grab does not engage, remove from service and contact your distributor or Tractel Ltd.

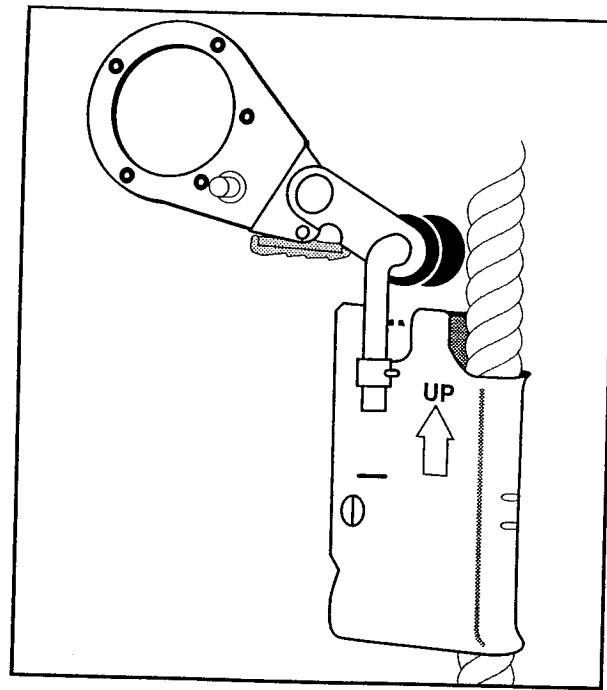

Figure 5

9.9 Always position the Gripgrab® rope grab at shoulder level to limit free fall distance. Do not hold the rope grab's cam lever in the open position while moving or at rest. Holding the Gripgrab® rope

grab's cam lever in the open position could interfere with proper operation should a fall occur. The Gripgrab® rope grab should be smoothly movable along on the lifeline.

! WARNING: ONE PERSON PER FALL ARREST SYSTEM !

DO NOT use the rope grab unless (1) it is fully locked close and on the lifeline with the arrow up, (2) safety locking pin is securely in place, and it locks on the lifeline when tested / pulled down.

Marking

10. Read all markings on the rope grab (see Figure 5 and 6).

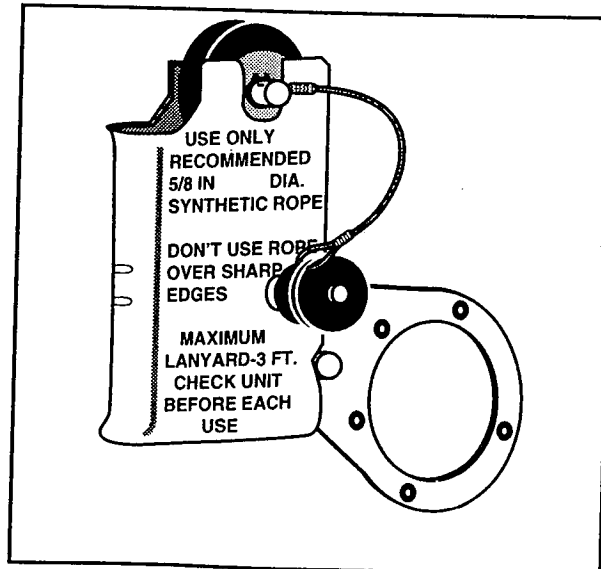

Figure 6

Cleaning Storage and Maintenance

11. The Gripgrab® rope grab needs little maintenance other than periodic cleaning and inspection (see 12.1). Use mild detergent and cool water to remove dirt, mud, etc. and then dry all parts thoroughly. All fall arrest equipment should be stored in a dry, cool location.

Inspection of System Components

12.1 All equipment must be inspected visually before each use by user and periodically by a qualified person. If damage is found as described below, remove the item from service immediately and replace it. If any damage or questionable conditions are apparent that are not described below (see 12.3), remove the item from service immediately, replace it and call Tractel Ltd. for advice.

12.2 Failure to remove equipment that has been damaged or has questionable condition could lead to serious or fatal injury. A detailed record of inspection should be maintained. See page 11 for suggested record sheet.

12.3 **Rope Grabs:** All rope grabs should be inspected (see Figure 7) to ensure that:

a) Roller cam assembly (a) at the top of the rope grab is clean, smooth, and moves freely.

b) When depressing button of the safety locking pin (b) and pulling it out, it should pull out from main assembly smoothly and quickly.

Swing cam and lever mechanism up and away to open up rope channel.

c) Rope channel (c) inner surface is smooth and clear, and metal is not bent or dented.

d) O-ring (d) is not bent or distorted in shape.

Swing cam and lever mechanism back into place and re-insert safety locking pin.

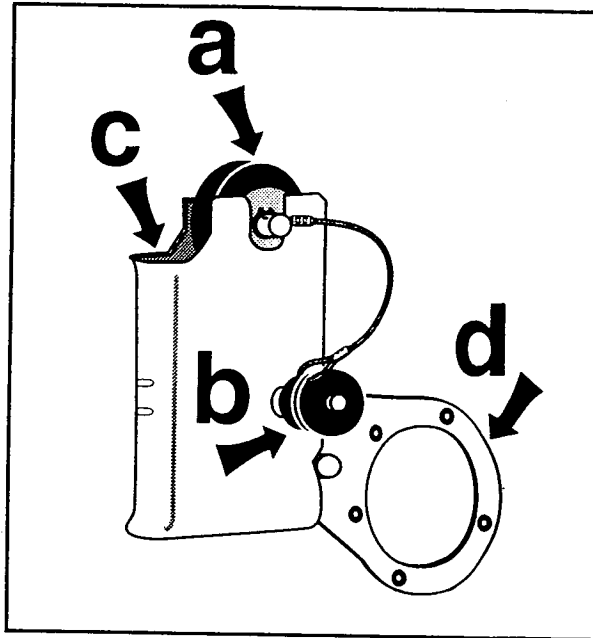

Figure 7

- e) Safety locking pin (b) push back into place and lock without sticking or jamming.
- f) Spring is intact and not clogged with dirt.
- g) Distortion, alteration or other damage is not evident.
- h) Excessive build up dirt or foreign matter does not interfere with operation.

⚠ WARNING

Look to see that all the rope grab markings are legible. If illegible replace rope grab.

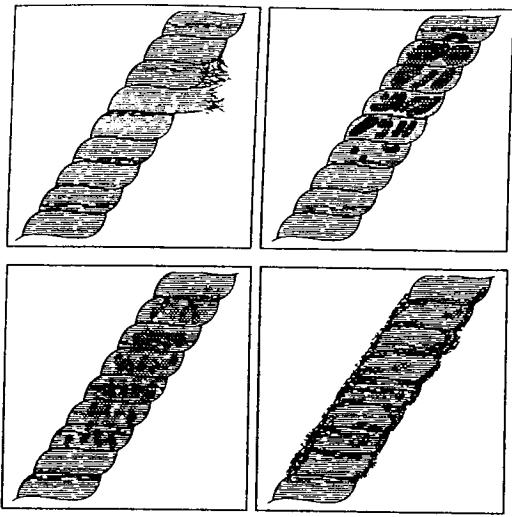

Figure 8

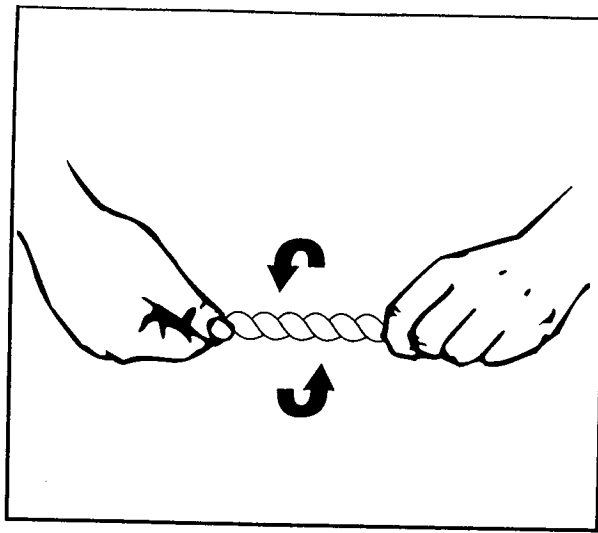

Figure 9

12.4 **Lifeline:** It should be inspected for any broken, cut, worn, burned (see Figure 8) or otherwise damaged rope strands by rotating the rope (see Figure 9). Fading of color is a mark of ultraviolet damage which may indicate a need of testing or replacement. The lifeline should be free of any loose materials such as dirt, sand or other materials as this could interfere with the overall function of the Gripgrab® rope grab. Confirm that the eye splice is tight around the lifeline thimble. If the thimble is missing or the splice is loose, the lifeline must be replaced. The lifeline surface must be free of any kind of petroleum or chemical contaminants. **If the lifeline has any dam-**

age, it is to be removed from service.

12.4.1 Lifeline should be cleaned periodically using mild detergent and cool water and then hung to dry in a cool area. Do not use any cleaning solvents, agents, acids, etc. on the lifelines, this may seriously damage the lifeline.

12.5 **Hardware:** Check the buckles, D-rings, grommets (metal eyelets on the belt), plastic sliders and wear pads for the following defects:

- a) damage, distorted or broken items;
- b) sharp edges, burrs, cracks corrosion or worn parts.

Also make sure that:

- a) all grommets are tight and intact;
- b) buckles do not operate properly and

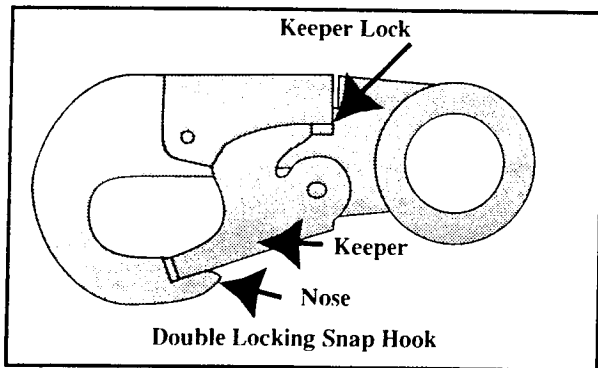

Figure 10

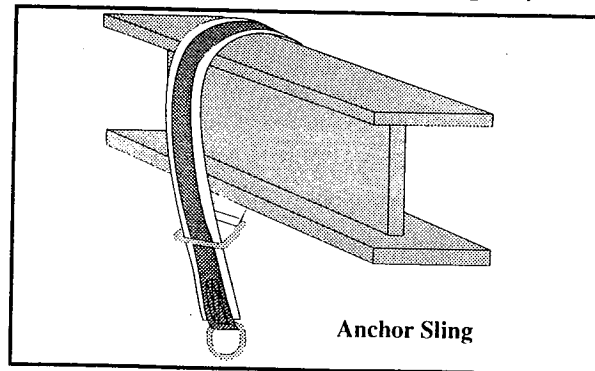

Figure 11

freely.

12.5.1 **Double locking snap hook:** The keeper should sit on the nose without binding and should not be distorted or obstructed. The keeper spring should exert enough force to firmly close the

keeper. The keeper lock must prevent the keeper from opening when closed (see Figure 10).

ATTENTION: Discoloration, pitted and cracked rivets are an indication of chemical corrosion.

Always use double locking snap hooks to reduce possibility of roll out.

12.6 **Lanyards:** All lanyards should be free of burns, cuts, fraying or knots. If a lanyard has been subjected to a fall or impact, it should be removed from ser-

vice and destroyed.

12.6.1 Never wrap a lanyard around a sharp or rough anchor point. Use a Fallstop® anchor sling for wrapping around the surface and connect the lan-



WARNING



yard to the sling (see Figure 11) or provide equivalent protection.

Any equipment that fails to meet the above inspection requirements shall be removed from service. Only Tractel Ltd., or persons or legal entities authorized in writing by Tractel Ltd., shall make repairs to Fallstop® Fall Arrest Equipment.

Warranty Information

13.1 Tractel Ltd. warrants its equipment to be free from defects in material and workmanship under normal use and service.

13.2 Our obligation under this warranty is limited to repairing or replacing, at our option, any part of the unit which proves, under examination to our satisfaction, to be defective in material or workmanship. The item in question is to be returned to Tractel Ltd., upon authorization of the distributor, transportation prepaid, within six (6) months from the date the equipment was sold to the original purchaser. Return shipment must be prepaid.

13.3 Any parts proved to be defective upon inspection by Tractel Ltd., will be repaired or replaced at no cost.

13.4 The obligation under this warranty does not include labor or transportation costs or consequential damages of any kind.

13.5 Any defect in this equipment must immediately be brought to the attention of Tractel Ltd. The distributor will make arrangements with the factory for repairs or replacements of the parts within the terms of this warranty.

13.6 Tractel Ltd.'s obligation is limited to replacing parts and does not include the complete unit. The warranty is void on any unit that has been modified or tampered with, repaired by persons other than a factory representative or an authorized Tractel Ltd. distributor, repaired with other than Tractel Ltd. standard parts, or damaged by reasons of accident, alteration, misuse or abuse.

13.7 This warranty is in lieu of all other warranties, expressed or implied. We do not authorize any person or representative to make any other guarantee or to assume for us any liability in connection with the sale of our appliances other than those contained herein. Any agreement outside of or contradictory to the foregoing shall be void and of no effect.

Purchasing date	Service entry date	User's name
-----------------	--------------------	-------------

Inspection check List: Serial No.

DATE	INSPECTION NOTE	CORRECTIVE ACTION TAKEN	INSPECTION PERFORMED BY:	SIGNATURE
	PASS <input type="radio"/> FAIL <input type="radio"/>	RETURN TO REPAIR <input type="radio"/> DESTROY <input type="radio"/>		
	PASS <input type="radio"/> FAIL <input type="radio"/>	RETURN TO REPAIR <input type="radio"/> DESTROY <input type="radio"/>		
	PASS <input type="radio"/> FAIL <input type="radio"/>	RETURN TO REPAIR <input type="radio"/> DESTROY <input type="radio"/>		
	PASS <input type="radio"/> FAIL <input type="radio"/>	RETURN TO REPAIR <input type="radio"/> DESTROY <input type="radio"/>		
	PASS <input type="radio"/> FAIL <input type="radio"/>	RETURN TO REPAIR <input type="radio"/> DESTROY <input type="radio"/>		

Contact the nearest Tractel Ltd. office.

In the United States:

1-800-742-6603
P.O. Box 68
Westwood MA, 02090
Fax: (617) 329-6530

In Canada:

1-800-268-1000
17 Metropolitan Rd.
Scarborough ON, M1R 2T5
Fax: (416) 298-8012

West Coast branch office

(510) 782-8965
28312 Industrial Ave, Unit C
Hayward CA, 94945
Fax: (510) 786-9104

1-800-561-3229

11020 Mirabeau
Anjou Qc, H1J 2S3
Fax: (514) 493-3342

Fallstop® is a registered trademark of Tractel Ltd.